

3,622" x 3,622" x 1,496" 92 x 92 x 38 mm

113XP

ETRI[®]

400 Hz Fans

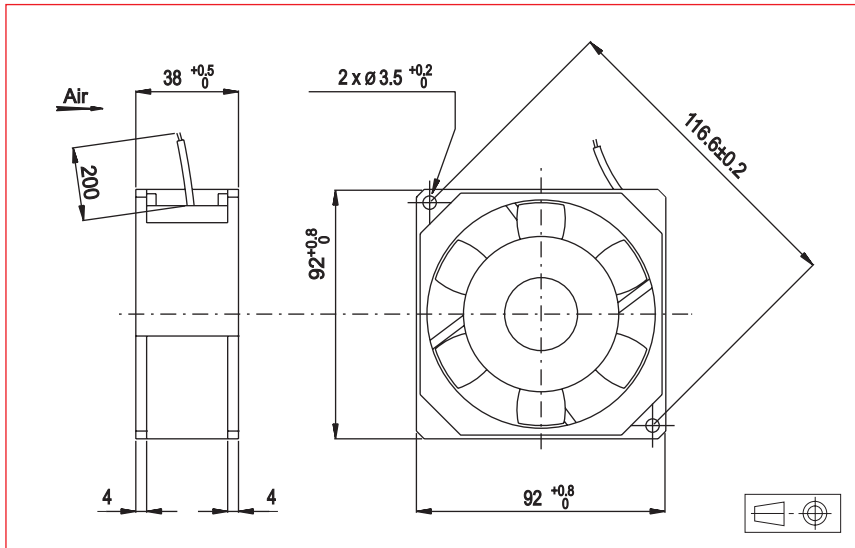

Approvals

NATO codification (not on all part numbers, please consult the factory for more detailed information)

Life expectancy

L-10 LIFE AT 40°C:
35 000 hours

400 Hz Motor

Housing material: aluminium
Impeller material: plastic UL 94 VO
Weight: 480 g
Bearing system: ball bearings

Connection: flying leads

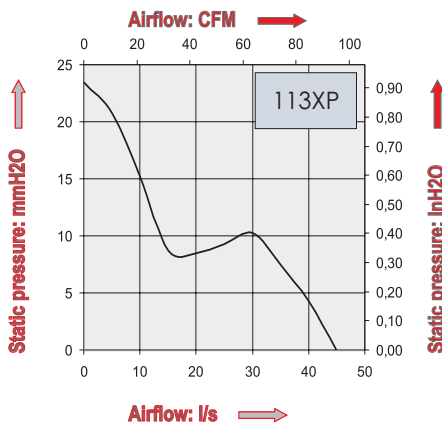

Part Number	Nominal voltage	Airflow		Noise level	Nominal speed	Phases	Capacitor (not included)	Input power	Nominal Current	Starting Current	Operating temperature	
	V	l/s	Cfm	dB(A)	RPM		µF	W	mA	mA	Min.°C	Max.°C
113XP0162001	115	45	95,3	58	5500	3		19	180	435	-10	70
	115	45	95,3	58	5500	1	0,69	20	200	350	-10	70
113XP0160001	200	45	95,3	58	5500	3		19	105	250	-10	70
	200	45	95,3	58	5500	1	0,22	20	110	200	-10	70

Additional versions:
Salt spray protected - Shock and vibration protected - Marine specifications
Wide temperature range