

AC Axial Fans

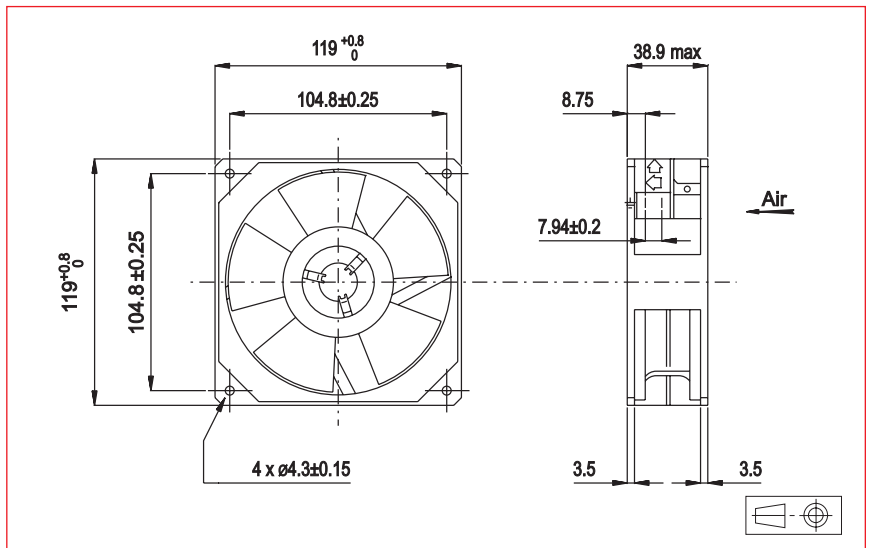

Approvals



Life expectancy

L-10 LIFE AT 40°C:
80 000 hours

AC Motor

Electrical protection: impedance protected
Housing material: zamak
Impeller material: plastic UL 94 V0
Maximum weight: 725 g
Bearing system: ball bearings
Connection: terminals

Single phase
IP 20

Available with:

- Flying leads
- IP 54
- Speed sensor

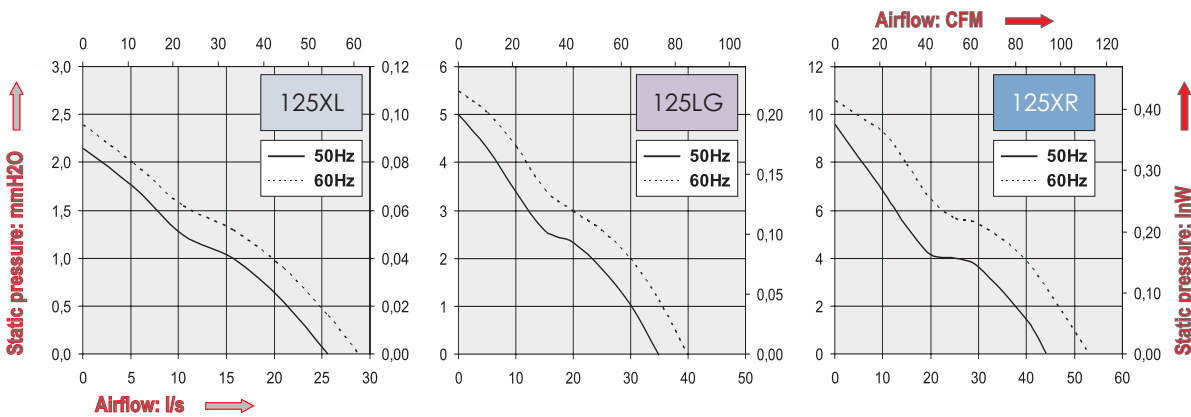

Part Number	Nominal voltage	Airflow	Noise level	Nominal speed	Frequency	Input Power	Nominal current	Starting current	Operating temperature	
	V								l/s	dB(A)
125XL0182001	115	25	30,0	1600	50	12	135	145	-10	70
		27	32,0	1750	60	10	115	125	-10	70
125XL0181001	208-240	25	30,0	1600	50	12	75	90	-10	70
		27	32,0	1750	60	10	65	75	-10	70
125LG0182001	115	35	38,0	2200	50	16	200	260	-10	70
		40	40,5	2500	60	13	160	120	-10	70
125LG0181001	208-240	35	38,0	2200	50	18	110	140	-10	70
		40	40,5	2500	60	15	90	120	-10	70
125XR0182001	115	44	44,0	2800	50	16	200	310	-10	70
		53	48,0	3200	60	15	180	260	-10	70
125XR0181001	208-240	44	44,0	2500	50	18	125	170	-10	70
		53	48,0	3200	60	15	105	150	-10	70

Additional versions:

Other weight: 560g with aluminium housing - Dual voltage 115V - 230V - other voltages
Salt spray protected - shock and vibration protected - marine specifications - wide temperature range