

4,724" x 4,724" x 1,496"

120 x 120 x 38 mm

125XR5

**ETRI**

AC Axial Fans

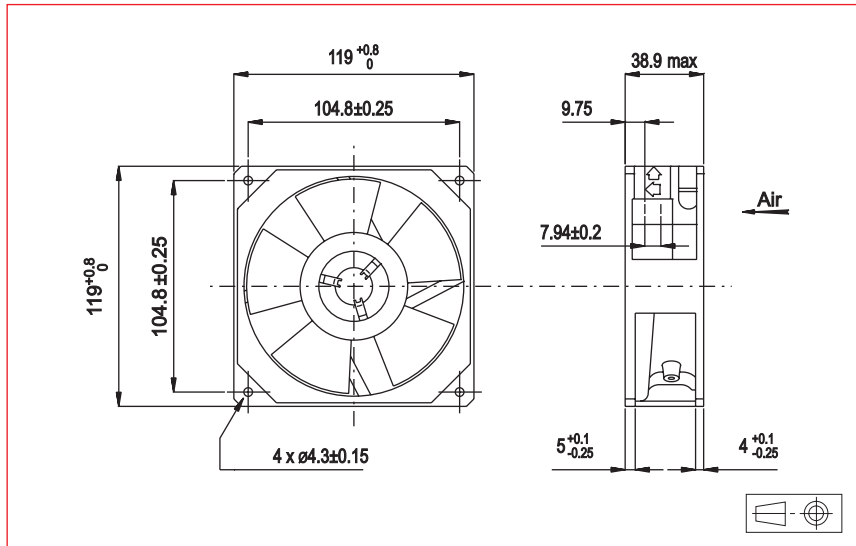

**Approvals**



**Life expectancy**

L-10 LIFE AT 40°C:  
80 000 hours

**AC Motor**

Electrical protection: impedance protected  
Housing material: aluminium  
Impeller material: plastic UL 94 V0  
Maximum weight: 560 g  
Bearing system: ball bearings  
Connection: terminals

Single phase  
IP 20

**Available with:**

- Flying leads
- IP 54
- Speed sensor

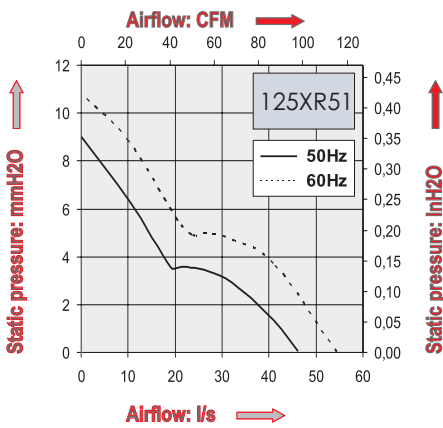

Part Number	Nominal voltage	Airflow	Noise level	Nominal speed	Frequency	Input Power	Nominal current	Starting current	Operating temperature	
	V								l/s	dB(A)
125XR5182002	115	44	43	2800	50	16	200	310	-54	100
		53	48	3200	60	15	180	260	-54	100
125XR5181002	208-240	44	43	2800	50	18	125	170	-54	100
		53	48	3200	60	15	105	150	-54	100

**Additional versions:**

Dual voltage 115V - 230V - other voltages  
Shock and vibration protected - salt spray protected - marine specifications