

AC Axial Fans

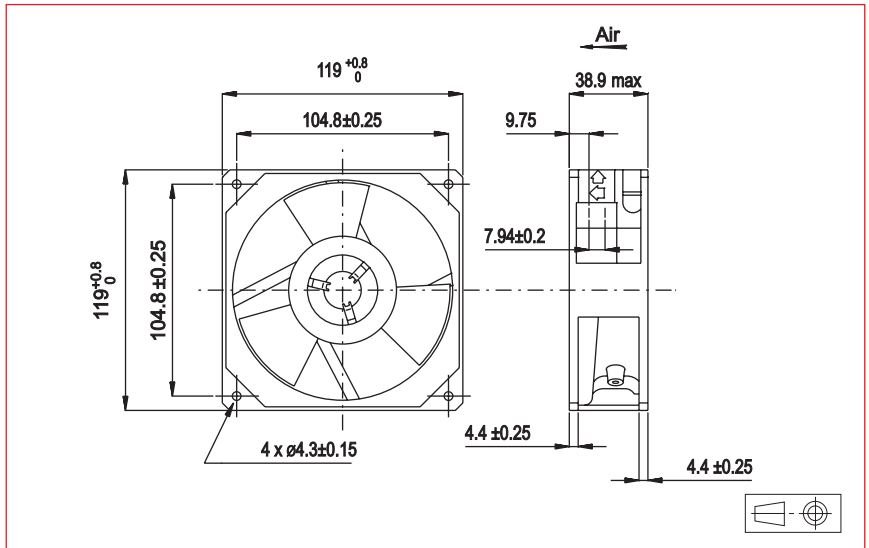

Approvals



Life expectancy

L-10 LIFE AT 40°C:
80 000 hours

AC Motor

Electrical protection: impedance protected
Housing material: zamak
Impeller material: plastic UL 94 V0
Maximum weight: 725 g
Bearing system: ball bearings
Connection: terminals

Single phase
IP 20

Available with:

- Flying leads
- IP 54
- Speed sensor

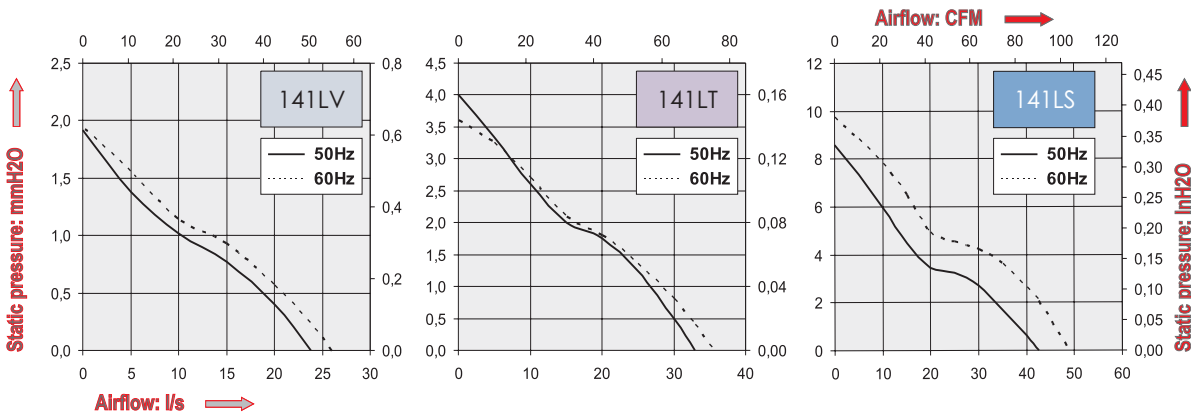

Part Number	Nominal voltage	Airflow	Noise level	Nominal speed	Frequency	Input Power	Nominal current	Starting current	Operating temperature	
	V	l/s	dB(A)	RPM	Hz	W	mA	mA	Min.°C	Max.°C
141LV0182001	115	23,5	27,5	1600	50	9	110	125	-10	70
		26,0	28,0	1700	60	8	100	110	-10	70
141LV0181001	208-240	23,5	27,5	1600	50	10	60	70	-10	70
		26,0	28,0	1700	60	9	55	65	-10	70
141LT0182001	115	33,0	35,0	2200	50	10	125	160	-10	70
		35,0	38,5	2400	60	9	110	140	-10	70
141LT0181001	208-240	33,0	35,0	2200	50	12	75	90	-10	70
		35,0	38,5	2400	60	10	65	75	-10	70
141LS0182001	115	42,0	44,5	2800	50	13	160	275	-10	70
		48,0	49,5	3200	60	12	140	240	-10	70
141LS0181001	208-240	42,0	44,5	2800	50	14	95	150	-10	70
		48,0	49,5	3200	60	12	80	130	-10	70

Additional versions:

Other voltages
Shock and vibration protected - salt spray protected - marine specifications - wide temperature range