

Ø 3,15" x 0,984"

Ø 80 x 25 mm

146DF

**ETRI**<sup>®</sup>

AC Axial Fans

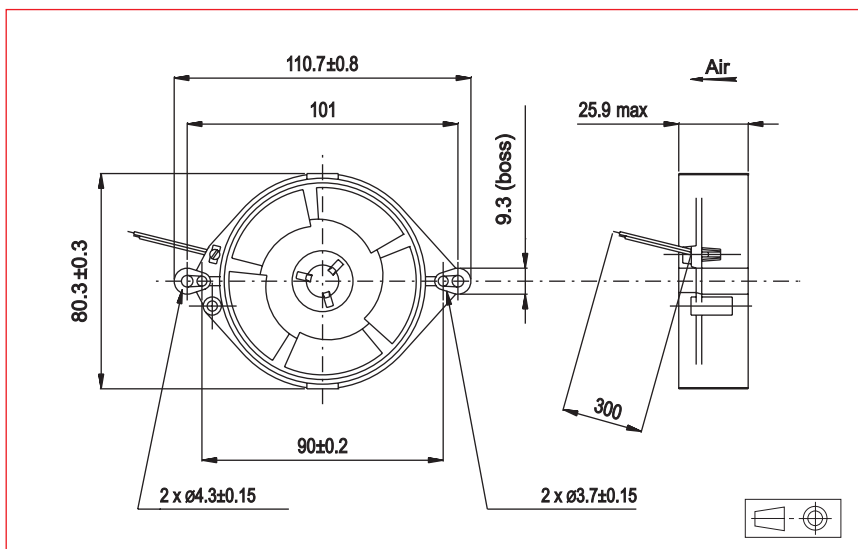

Approvals



Life expectancy

L-10 LIFE AT 40°C:  
80 000 hours

AC Motor

Electrical protection: impedance protected  
Housing material: zamak  
Impeller material: plastic UL 94 V0  
Maximum weight: 300 g  
Bearing system: ball bearings  
Connection: flying leads

Single phase  
IP 20

Available with:

- IP 54
- Non RoHS on request

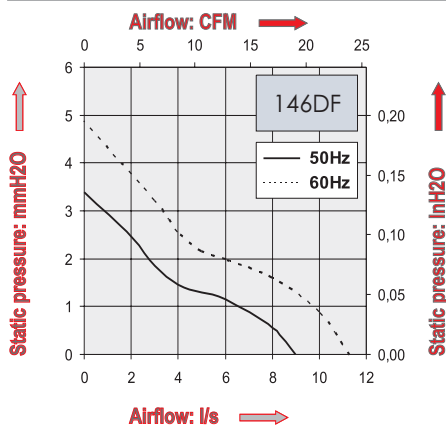

Part Number	Nominal voltage	Airflow	Noise level	Nominal speed	Frequency	Input Power	Nominal current	Starting current	Operating temperature	
	V	l/s	dB(A)	RPM	Hz	W	mA	mA	Min.°C	Max.°C
146DF0182001	115	9	26	2500	50	10	105	120	-10	70
		11	32	3100	60	8	90	110	-10	70
146DF0181001	208-240	9	26	2500	50	11	60	70	-10	70
		11	32	3100	60	9	50	60	-10	70

Additional versions:

Shock and vibration protected - salt spray protected - marine specifications - wide temperature range