

3,622" x 3,622" x 0,984" 92 x 92 x 25 mm

Series
99X

ETRI

AC Axial Fans

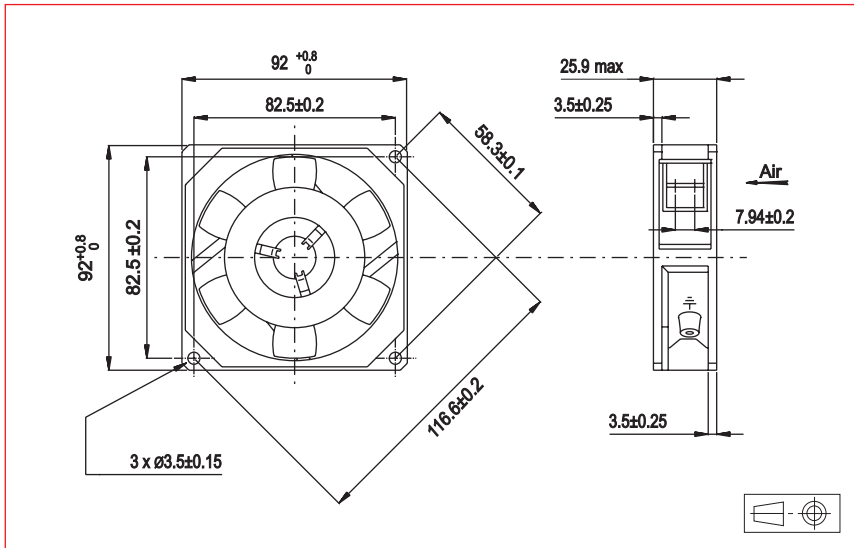

Approvals



Life expectancy

L-10 LIFE AT 40°C:
80 000 hours

AC Motor

Electrical protection: impedance protected
Housing material: zamak
Impeller material: plastic UL 94 V0
Maximum weight: 395 g
Bearing system: ball bearings
Connection: terminals

Single phase
IP 20

Available with:

- Speed sensor - IP 54
- Flying leads

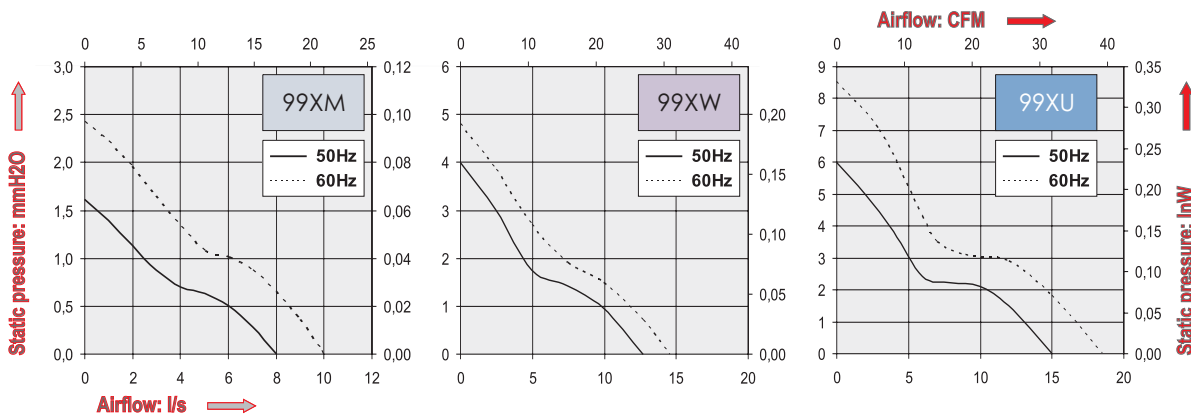

Part Number	Nominal voltage	Airflow	Noise level	Nominal speed	Frequency	Input Power	Nominal current	Starting current	Operating temperature	
	V								l/s	dB(A)
99XM0182001	115	8,0	21,0	1500	50	7	75	80	-10	70
		10,0	25,5	1800	60	6	65	70	-10	70
99XM0181001	208-240	8,0	21,0	1500	50	8	40	45	-10	70
		10,0	25,5	1800	60	7	35	40	-10	70
99XW0182001	115	12,0	32,0	2200	50	8	85	100	-10	70
		14,0	35,5	2500	60	6	70	90	-10	70
99XW0181001	208-240	12,0	32,0	2200	50	9	50	60	-10	70
		14,0	35,5	2500	60	7	40	50	-10	70
99XU0182001	115	15,0	38,0	2700	50	14	70	100	-10	70
		18,5	42,0	3200	60	11	60	90	-10	70
99XU0181001	208-240	15,0	38,0	2700	50	14	70	100	-10	70
		18,5	42,0	3200	60	11	60	90	-10	70

Additional versions:

Salt spray protected - Shock and vibration protected - marine specifications - wide temperature range